



AT-7000 Series

MULTIFUNCTIONAL COMMUNICATIONS & SIGINT ANTENNA SYSTEM

FEATURES

- Multifunctional communications and SIGINT antenna system
- Extended operation range: 10kHz - 6GHz
- VLF/HF-Rx 2G, 4G, 5G, WIFI & SIGINT capabilities
- Combined Communications-SIGINT interface
- Form-fit same as AT-4000 series multifunctional communications antenna system





AT-7000 Series

The AT-7000 antenna system was developed for terrestrial and non-terrestrial communications and SIGINT (COMINT & ELINT). As a communications antenna system, it offers communication technologies such as VLF/HF-Rx, VHF, UHF, IFF, Link-16, GPS, Inmarsat C, Iridium, as well as 2G, 4G, 5G and WIFI. As a SIGINT antenna system, it routes received COMINT and ELINT signals to the signal analyzer and recorder system for further evaluation and emitter detection. The antenna elements are enclosed in a pressure-proof and seawater-resistant radome and installed on a flange with a low magnetic signature.

ELECTRICAL DATA

Functions	Frequency Band (MHz)	Radiation Pattern (E/H-planes)	Communication Mode	Antenna Gain (dBi) approx.	VSWR (Max.)	Max. Power Handling (W)
VLF/HF-Rx	0.01 - 30	H/Omni	Rx only	Rx only	3:1	Active Rx
VHF-Low	30 - 88	V/Omni	Full-Duplex	-8	3:1	50 CW
VHF-High	100 - 174	V/Omni	Full-Duplex	0 to 2	3:1	50 CW
UHF	220 - 512	V/Omni	Full-Duplex	0 to 2	3:1	50 CW
Link-16	960 - 1215	V/Omni	Full-Duplex	0 to 2	3:1	100 CW
IFF	980 - 1150	V/Omni	Full-Duplex	0 to 2	3:1	1000 P w. 2% D
2G/GSM	900, 1800	V/Omni	Full-Duplex	0 to 2	3:1	50 CW
4G/LTE	850, 1800, 2600	V/Omni	Full-Duplex	0 to 2	3:1	50 CW
5G	Sub-6GHz	V/Omni	Full-Duplex	-2 to 2	3:1	50 CW
WIFI	2400, 5000	V/Omni	Full-Duplex	-2 to 2	3:1	50 CW
GPS	L1, L2	RHCP/Omni	Rx only	0 to 5	2:1	Active Rx
Iridium	1610 - 1626.5	RHCP/Omni	Full-Duplex	0 to 5	2:1	50 CW
INMC-Rx	1530 - 1545	RHCP/Omni	Semi-Duplex	0 to 5	2:1	Active Rx
INMC-Tx	1626.5 - 1646.5	RHCP/Omni	Semi-Duplex	0 to 5	2:1	50 CW
SIGINT	0.01 - 6000	H, V/Omni	Rx only	-8, 0, 0 to 2	3:1	Active Rx

V = Vertical, H = Horizontal, D = Duty Cycle, P = Peak, CW = Continuous Wave.

Isolation between antenna elements incl. Filters is >30 dB; Impedance = 50 Ω; Connector Type N (F).

MECHANICAL DATA

Antenna	Diameter Length Weight	176 mm 1215 mm incl. non-pressure tight connectors* approx. 50 kg
Interface Module	Supply Voltage Power Consumption Dimension (L x W x H) Weight	115 VAC, 50 - 60 Hz RX: approx. 75 W, Tx: approx. 230 W 332 x 250 x 111 mm approx. 10 kg
Remote Control	Dimension (L x W x H) Weight	approx. 140 x 130 x 80 mm approx. 1 kg

*Also available with pressure tight connectors/base plate.

ENVIRONMENTAL DATA

Shock	Vertical Horizontal Vertical/Horizontal	165 g for 1 ms (typ.) 400 g for 1 ms (typ.) 55 g for 6 ms (typ.)
Temperature	Operating Non-Operating	-25°C to +55°C -40°C to +70°C
Pressure	Operating Tested	70 bar 90 bar

SIMULTANEOUS OPERATIONS

Functions	VLF/ HF-Rx	VHF-Low	VHF-High	UHF	Link-16	IFF	2G/GSM	4G/LTE	5G	WIFI	GPS	Iridium	INMC-Rx	INMC-Tx	SIGINT
VLF/HF-Rx	●	●	●	●	●	●	●	●	●	●	●	●	●	●	
VHF-Low	●	●	●	●	●	●	●	●	●	●	●	●	●	●	
VHF-High	●	●	●	●	●	●	●	●	●	●	●	●	●	●	
UHF	●	●	●	●	●	●	●	●	●	●	●	●	●	●	
Link-16	●	●	●	●	●										
IFF	●	●	●	●		●									
2G/GSM	●	●	●	●			●	●	●	●					
4G/LTE	●	●	●	●			●	●	●	●					
5G	●	●	●	●			●	●	●	●					
WIFI	●	●	●	●			●	●	●	●					
GPS	●	●	●	●							●		●		
Iridium	●	●	●	●								●			
INMC-Rx	●	●	●	●									●		
INMC-Tx	●	●	●	●										●	
SIGINT															●

SYSTEM BLOCK DIAGRAM

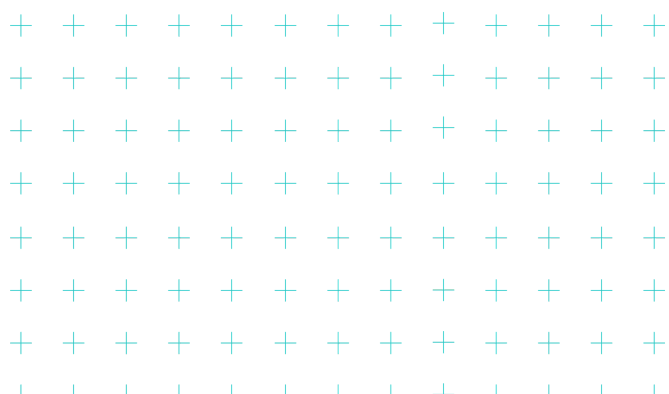
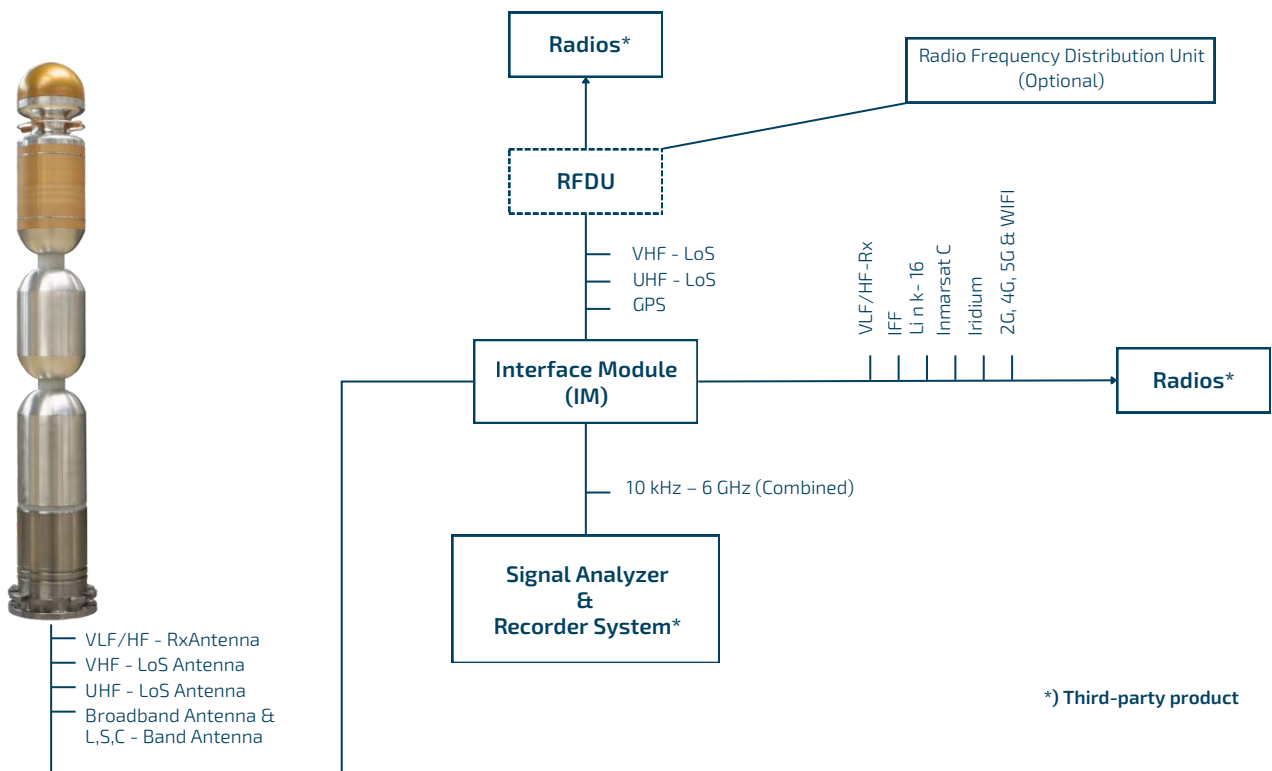

AT-7000 Series

RADIATION PATTERNS

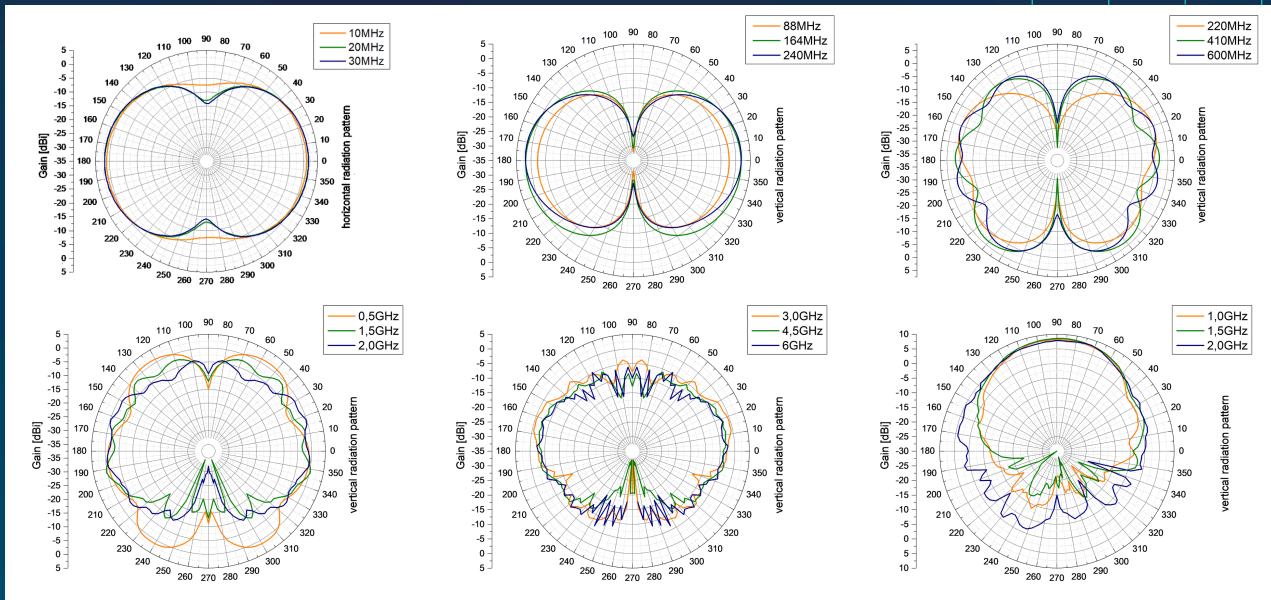

ACCESSORIES

Interface Module (IM)

As the name suggests, the interface module (IM) serves as an interface between the AT-7000 antenna and various radio devices. The main functions of the IM include supplying the electronic components in the IM itself and the antenna with DC power and control signals, switching between different communication links, and signal conditioning. The IM also features an integrated SIGINT module, while still maintaining a form-fit identical to the AT-4000 series IM. The SIGINT module controls the signals received via individual antenna elements of the AT-7000 antenna and provides an interface to the signal analyzer and the recording system.

Remote Control Unit (RCU)

The remote control is used to control the power supply to the interface module by manually turning the switches on and off. It instructs the interface module to switch between different RF links by engaging appropriate switches.

Radio Frequency Distribution Unit (RFDU)

The RFDU acts as an automatic switching matrix that provides interfaces between various antennas and radio devices.

AEROMARITIME
Systembau GmbH
Ludwig-Erhard-Straße 16
D-85375 Neufahrn
Germany

+49 8165 61 71-0

aeromaritimegroup.com